

MCQ questionnaire

1. Consider a point P located at the edge of a wheel. At the time $t = 0$ the point P is at the origin of the coordinate system. The wheel is now moving to the right, with a constant speed and parallel to the x . What is the path of point P?

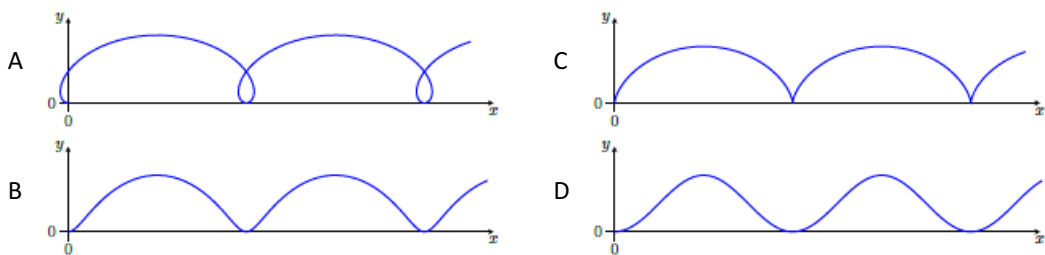

- a. A
 b. B
 c. **C**
 d. D
2. A ball is thrown from the top of a staircase with a speed of 1.5 m/s. Each step is 10 cm wide and 10 cm high; the steps are numbered 1, 2, 3, ... as shown in the diagram. On which step will the ball fall first?

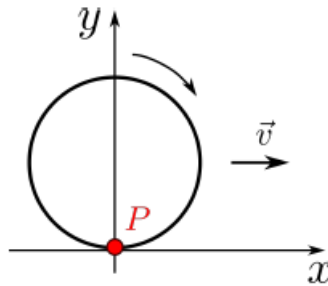
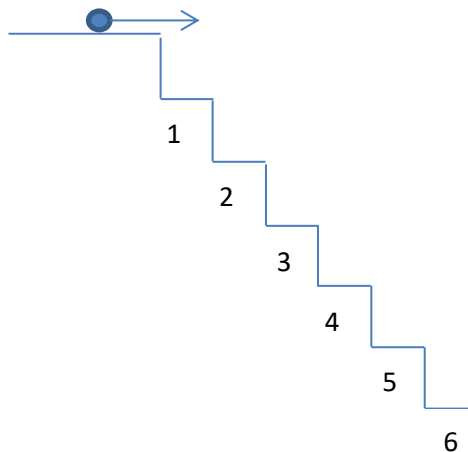

- a. 2
 b. 3
 c. 4
 d. **5**
3. Two blocks $m_1 = 2$ kg and $m_2 = 4$ kg are suspended from elastic wires of negligible mass. The wire just above the top block m_1 is cut instantaneously. What are the accelerations of the two blocks when the upper block starts to fall?

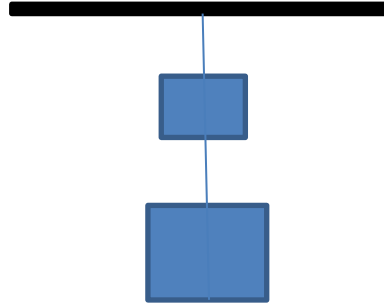

- a. m_1 10 m/s² m_2 : 0 m/s²
- b. m_1 10 m/s² m_2 10 m/s²
- c. m_1 30 m/s² m_2 10 m/s²
- d. **m_1 30 m/s² m_2 : 0 m/s²**

4. The power of a cube-shaped experimental object is proportional to its mass m . The air resistance experienced by the mobile is proportional to $A v^2$ where A is the cross-sectional area of the object and v its speed. The maximum speed on a horizontal surface is equal to v_{\max} . Assuming that all the models tested have the same density, which of the proportionality is correct for the maximum speed?

- a. $v_{\max} \propto m^{1/9}$
- b. $v_{\max} \propto m^{1/3}$
- c. $v_{\max} \propto m^{2/3}$
- d. $v_{\max} \propto m^{3/4}$

5. A workman invents a system for mixing the contents of barrels. He places a board of length 5 m on top of the barrel. The radius of the barrel is equal to 0.5 m (see diagram). The workman walks towards the board while holding the board in his hand. This way the barrel will rotate, and the contents will be mixed. The barrel does not slip in relation to the ground or the board.

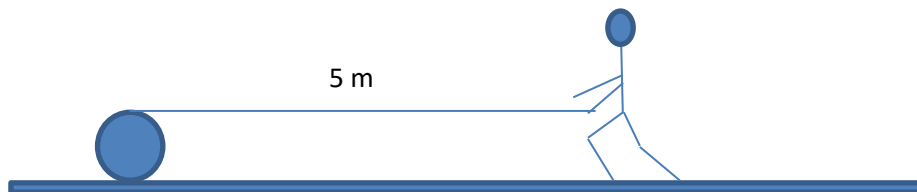

How far does he have to travel to reach the barrel?

- a. 4 m
- b. 4,5 m
- c. 8,5 m
- d. **9 m**

6. A ball without initial velocity rolls down an inclined plane of height h at an angle α with the horizontal direction. Friction is neglected and any change of direction happens without energy loss. When it reaches the bottom, the ball moves up another inclined plane with the same slope. Indicate the correct statement.

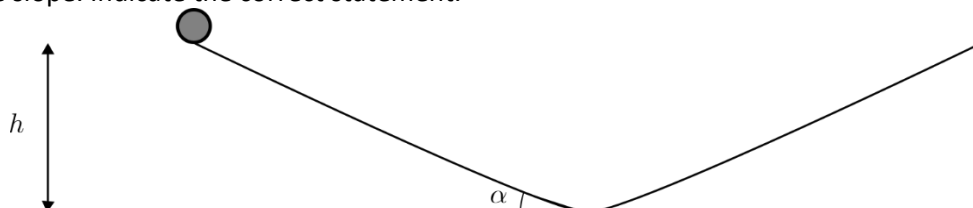

- a. the period of oscillation is independent of the initial height
- b. it is a harmonic oscillation
- c. the oscillation period is independent of the angle α

d. none of the above

7. Three lamps are connected in the circuit shown below. In this configuration, all the lamps shine with the same power. Remove the lamp L_3 from its socket without changing the rest of the circuit. What happens with the powers P_1 and P_2 of the two remaining lamps?

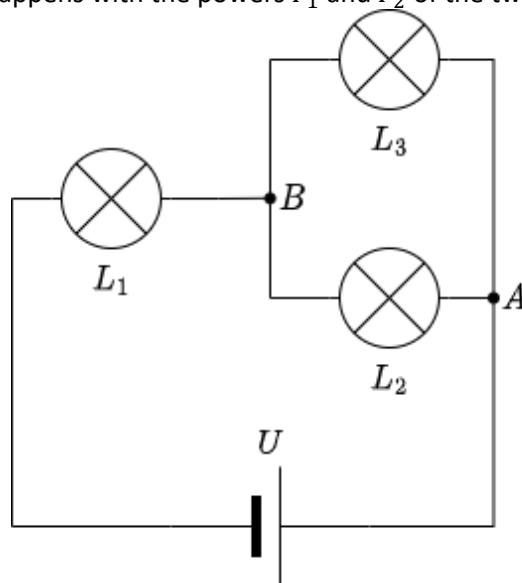

- a. $P_1 \searrow$ $P_2 \searrow$
- b. $P_1 \nearrow$ $P_2 \nearrow$
- c. $P_1 \searrow$ $P_2 \nearrow$
- d. $P_1 \rightarrow$ $P_2 \nearrow$
- e. $P_1 \rightarrow$ $P_2 \rightarrow$

8. A basketball is released without initial velocity, falls freely to the ground and then bounces back up to the same height. Indicate the graph that represents this movement.

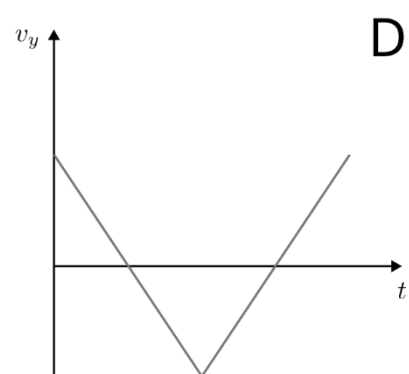
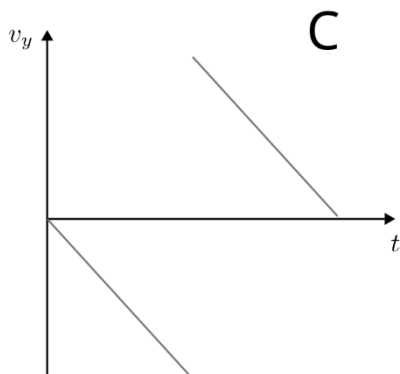
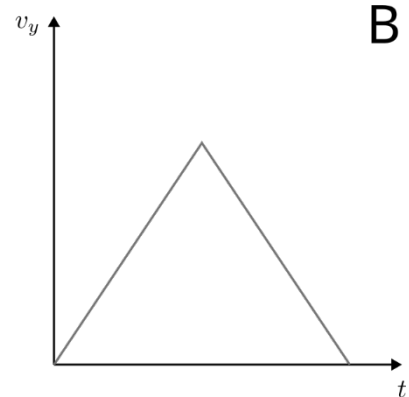
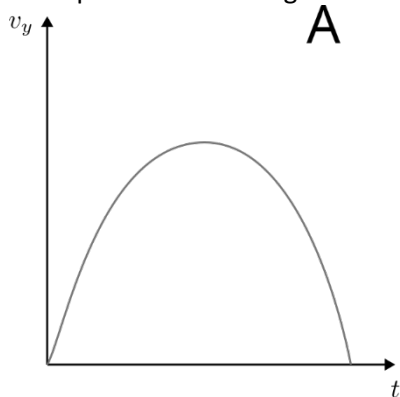

- a. A
- b. B

- c. **C**
 d. D
 e. none of the above
9. A certain car travelling at 20 km/h can stop within a distance of 10 m when braking without the wheels spinning. Under the same braking conditions, what would be the braking distance with a speed of 40 km/h?
- a. 5 m
 b. 10 m
 c. 20 m
 d. **40 m**
 e. 80 m
10. Which of the following statements is true about a small artificial satellite orbiting the Earth?
- a. the larger the radius of its path, the greater its speed
 b. the higher its mass, the longer it takes to go around the Earth
 c. **the larger the radius of its path, the longer it takes to go around the Earth**
 d. if it rotates from east to west, it takes longer to circle the Earth (relative to the stars) than if it rotates from west to east
11. Which explanation is not correct for the fact that the two levels are at different heights in the drawing below?

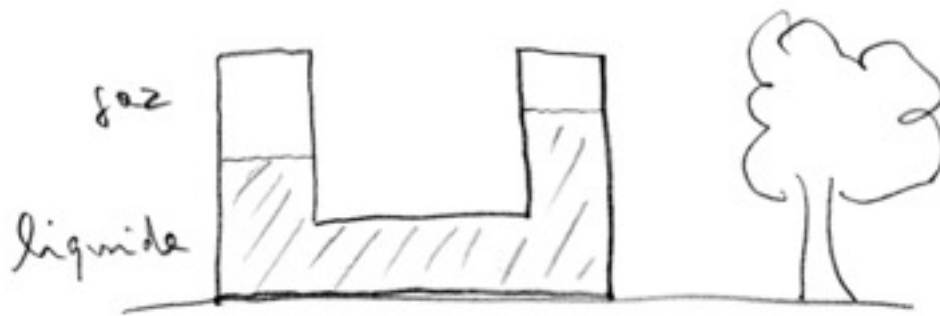

- a. the pressure of the gas above the liquid could be greater on the left than on the right
 b. it could be that we have two liquids with different densities
 c. levels are shifting
 d. there could be an invisible wall in the liquid part
 e. **the floor in the photo is not horizontal (the drawing has been turned slightly)**
12. A jet of water emerges from the surface of a pond at an angle of 15° with the vertical so that the water falls back onto the surface 5 m away. Neglecting air resistance, what is the best estimate for the speed of the water when it hits the surface of the pond?
- a. 5 m/s
 b. **10 m/s**
 c. 15 m/s
 d. 20 m/s
13. Consider a cylindrical tube of length 10 m containing two gases separated by a piston of negligible mass.

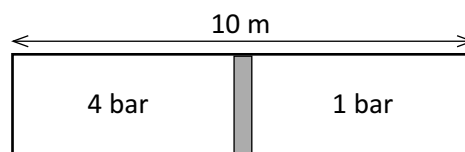

Initially, the piston is fixed in the middle of the tube, the pressures of the two gases are 4 bar and 1 bar respectively. The piston is then released and moves to its new equilibrium position, the temperature remaining constant. How much has the piston moved?

- a. 1 m
- b. 2 m
- c. **3 m**
- d. 4 m

14. Consider the following circuit:

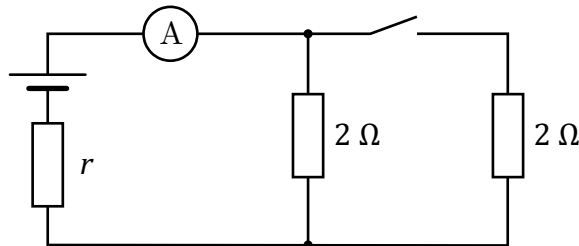

The battery has a no-load voltage (emf) of 6 V and a significant internal resistance r . When the switch is open, the ammeter shows a current of 2 A. What is the reading of the ammeter when the switch is closed?

- a. 1 A
 - b. 2 A
 - c. **3 A**
 - d. 4 A
15. A person hits a long straight rail sharply with a hammer. Two sound waves propagate in the air with 340 m/s and in the rail with 5.6 km/s respectively. A second person stands at a distance d from the first person and perceives the two waves with a delay of 5 s. What is the distance d ?
- a. 1.7 km
 - b. **1.8 km**
 - c. 2.8 km
 - d. 28 km
16. A child pulls his 6 kg sled by means of a string up a snowy slope with a 15° inclination at a constant speed. The tension in the string is 25 N and the string is at an angle of 20° with the ground. What is the value of the coefficient of kinetic friction?
- a. 0,10
 - b. 0,13
 - c. **0,17**
 - d. 0,20
17. The figure shows the cross-section of a prism of index n placed in water of index $4/3$. It is an equilateral triangle with sides of 5 cm. When a beam of light strikes the side AB at an angle α , it emerges, at least partially, from the AC side. When we decrease α , it is necessary to wait until α becomes zero so that the beam no longer emerges from side AC at all, but from side BC. Calculate the refractive index of the glass.

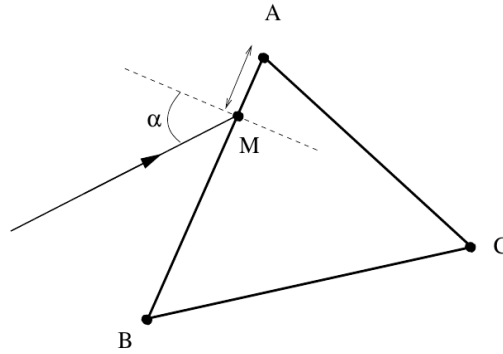

- a. 1,49
- b. 1,51
- c. **1,54**
- d. 0,49

18. An electron moves on an orbit around a proton in a hydrogen atom. A weak magnetic field is applied, normal to the plane of the orbit. If the radius of the orbit does not change, then the change in angular velocity $\Delta\omega$ of the electron in circular motion is:

- a. $\pm \frac{2eB}{m}$
- b. $\pm \frac{e^2 B}{m}$
- c. $\pm \frac{eB}{8m}$
- d. $\pm \frac{eB}{2m}$

19. A tuning fork vibrates at a frequency of 512 Hz. If the sound propagates at 345 m/s, how many wave crests reach the eardrum of a person sitting near the fork in 2 seconds?

- a. about 225
- b. about 450
- c. a little less than 500
- d. **just over 1000**
- e. far more than 2000

20. Blaise Pascal claimed that he could destroy a full barrel with a few glasses of water. Pascal then drilled a hole in the top of the barrel and inserted a thin tube several meters long. After carefully sealing the barrel, he poured water into the pipe. The thin pipe filled quickly and suddenly the barrel burst with a loud crash. The barrel had a capacity of 500 liters and was 1.0 m high. The riser pipe had a cross-sectional area of 1 cm^2 . Calculate how many glasses of water, each containing 0.3 litres, Pascal had to pour into the rising pipe so that the bottom pressure in the barrel quadrupled.

- a. **1 jar**
- b. $1 \frac{1}{2}$ glasses
- c. Half a glass
- d. Another barrel full
- e. the barrel cannot burst because it is too strong

